

CROOZER

Owner's manual



CROOZER MINI

Table of contents

1	Assembly	2
1.1	Parts.....	2
1.2	Removal and Assembly of the Wheels.....	2
2.	Functions	3
2.1	Unfolding, Locking and Folding up the Fabric Assembly.....	3
2.2	Safety Flag.....	3
2.3	Hitch Arm Installation.....	4
2.4	Stroller Functions.....	4
3.	Initial Operation	4
3.1	Fixing the Hitch Arm on the Bicycle.....	4
3.1.1	Fitting the Coupling Unit to the Bicycle.....	5
3.1.1.1	Bicycle with Solid Bolt-on Axle.....	5
3.1.1.2	Bicycle with Quick Release Axle.....	5
3.1.2	Fitting the Hitch Arm to the Coupling Unit.....	5
3.2	Distributing the Load Carried.....	7
4.	Safety Instructions and Warnings	7
5.	Service, Care and Storage	8
5.1	Hitch Arm	8
5.2	Wheels	8
5.3	Fabric Assembly	8
5.4	Storage.....	8
5.5	General Maintenance	9
5.6	Wear Factors.....	9

Congratulations on buying the Croozer multipurpose mini carrier.



Your new CROOZER MINI stands out because of its excellent quality, user-friendliness, practicality, and high performance as a transport carrier.

If you have any questions or concerns about your carrier please ask your retailer for help.

1. Assembly

1.1 Parts



Frame with fabric assembly (folded), 2 wheels, front stroller wheel, handlebar, hitch arm with coupling, safety flag, and wrench

1.2 Removal and Assembly of the Wheels



To remove the wheel loosen nut with supplied wrench until axle is completely free of the carrier.



Pull off the wheel and axle.

Assembly of the wheel is the reverse of the above

2. Functions

2.1 Unfolding, Locking and Folding up the Fabric Assembly



First open out the sidewall that is on the right in the direction of travel.



Then open out the sidewall that is on the left in direction of travel.



Open the rear window and the rear roof flap that is on the right in direction of travel.



Swivel out the rotating upper diagonal tube of the sidewall that is on the left in direction of travel



until it engages in its counter bearing on the right sidewall.

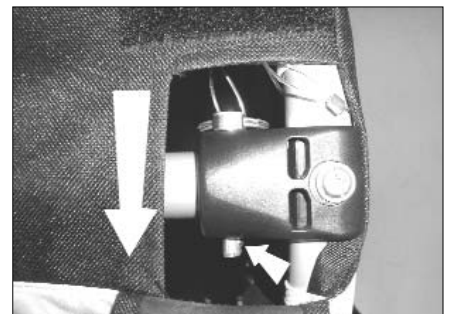

Insert the securing pin through the aligned holes of the diagonal tube and its counter bearing until the small spring-loaded ball engages behind the counter bearing.

Please note:

Always make sure that the securing pin is inserted through both holes, i.e. that of the counter bearing as well as that of the diagonal tube. Your dog may be injured, if the assembly collapses due to an improperly secured diagonal tube.

Folding up of the assembly is the reverse of the above.



Always fold in the sidewall that is on the left in direction of travel first.



When folding in the right sidewall make sure that the front and rear walls are pressed inwards – this prevents damage to the assembly when it is completely folded up.

2.2 Safety Flag

A flap for fixing the safety flag is provided on the left at the carriers' rear end.

2.3 Installing the Hitch Arm



To install the hitch arm first remove the quick release skewer that is on the bracket on the left hand side of the carrier.

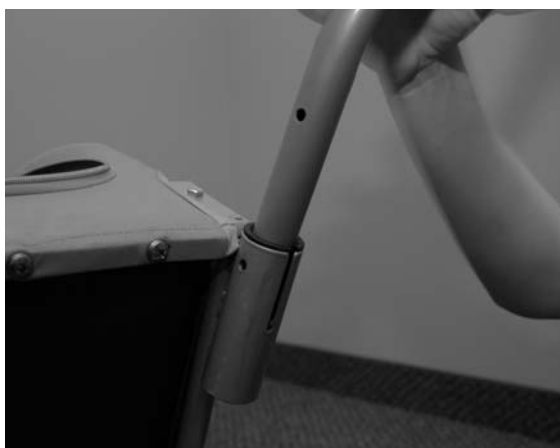

Then insert the hitch arm into the bracket, making sure the hitch faces toward the center of the carrier. Line up the holes in the hitch arm with those in the bracket.



Secure the hitch arm with the quick release skewer. Slide the skewer through the hole in the bracket and the hitch arm. Hand tighten the nut and close the quick release time.

2.4 Stroller Function

This section shows the front pivot wheel in use. It must be removed when trailering.

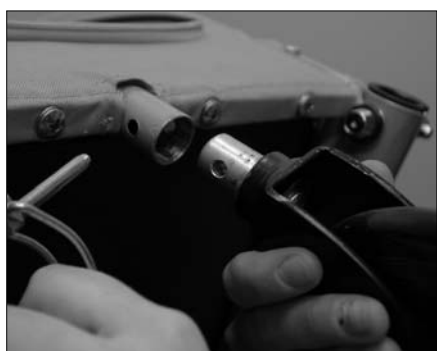

To install the stroller wheel, first insert stroller wheel into bracket at the front of the carrier.



Then insert the securing pin through lined up holes. Finally secure it by closing the safety clip.



To install the handlebars, line up the holes in the bracket and the handlebars.



Finally re-install the pins, from the outside towards the inside.



Engage the parking brake whenever the carrier is stopped. Simply push the lever to the right to engage the brake and push to the left to disengage the brake.

3. Initial Operation

3.1 Fixing the Hitch Arm on the Bicycle

3.1.1 Fitting the Coupling Unit to the Bicycle

Always fit the hitch arm and coupling on the left hand side in direction of travel!

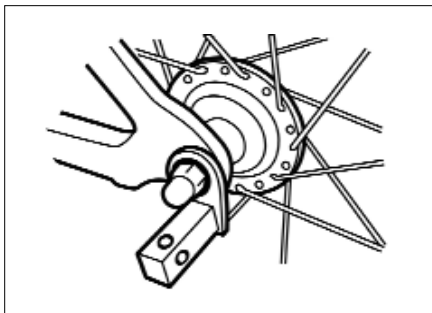

The coupling unit should always be attached in such a way that the square points vertically downwards when seen from the axle.

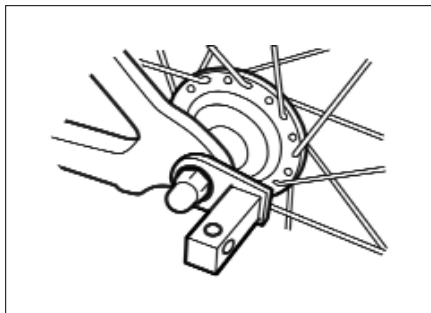

Only when the dropout or other features of your bicycle make vertical fitting impossible should the coupling unit be attached horizontally, pointing backwards.

Please note:

As the designs of dropouts can vary considerably, there may be a few isolated cases where it is impossible to attach the coupling in any position. If you are not sure how to attach the coupling correctly to your bicycle please ask your bicycle dealer.

Please note:

When the Croozer is used as a trailer behind a bicycle, your safety depends on the coupling being properly fitted. Proceed therefore with special care. Never cycle with a coupling that is inadequately attached or not secured. If in doubt ask your retailer!

3.1.1.1 Bicycle with Solid Bolt-on Axle



Remove the left hand axle nut. Any spacers or plain washers can generally be retained. Put the coupling unit on the axle and reattach the axle nut.

Please note:

The axle nut must be tightened on the axle thread by at least 5 full turns, so that adequate clamping force is ensured.

A thread which is too short can lead to accidental loosening of the rear wheel and could cause a serious accident. If in doubt ask your specialist dealer!

3.1.1.2 Bicycle with Quick Release Axle

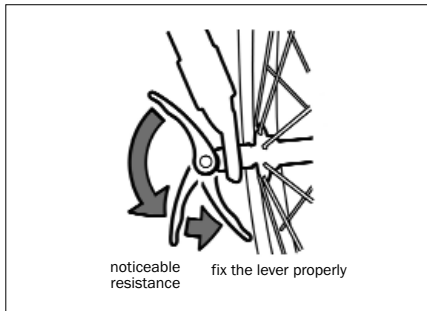

Please note:

If you do not feel confident when fitting the quick release for the first time, please ask your stockist.

Please note:

The thread of the adjusting nut of the quick release must be tightened on the quick release axle by at least 5 full turns, so that adequate clamping force is ensured. A quick release axle which is too short can lead to accidental loosening of the rear wheel and could cause a serious accident. If in doubt ask your specialist dealer!

Dismantle the quick release and guide the quick release axle through the coupling unit. Push the quick release through the hollow axle again and screw on the adjusting nut, tightening it in a clockwise direction until the contact surfaces of the quick release are up against the dropout. Close the quick release lever.

The quick release is properly adjusted when you can clearly feel resistance as you tighten. You should feel this resistance about 60° before the end of the lever movement. If it is too easy or too difficult to move the quick release lever, slightly tighten or loosen the Q.R. adjusting nut on the other side of the hub.

Tip: For bicycles where the length of the standard quick release is insufficient, a special quick release with longer axle is available.

3.1.2 Fitting the Hitch Arm to the Coupling Unit

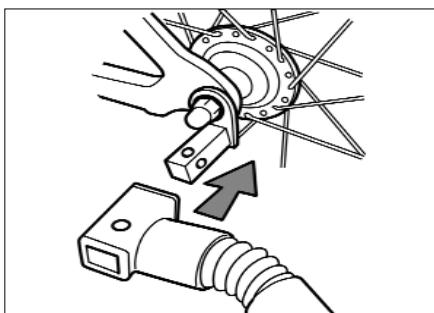

Push the square hitch arm connection over the coupling unit attached to the bicycle.

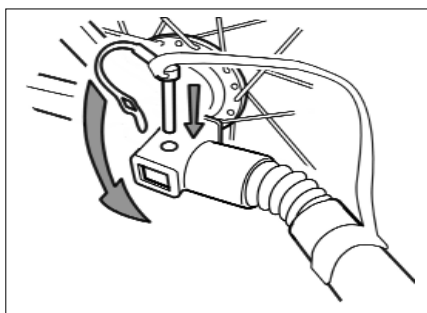

Insert the spring clip bolt through the boreholes of both coupling parts and close the clip so that the clip opening surrounds the bolt end.

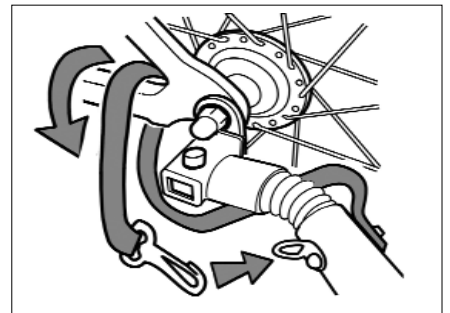

Please note:

Always attach the safety strap to the chain stay!

Put the safety tie around the rear section of the bicycle frame and fasten it to the hitch arm D-ring with the snap hook.

Please note:

A coupling, which is incorrectly fitted, could become loose and could slip sideways into the spokes during braking. There is considerable danger that the cyclist will fall or become injured. Please therefore always ensure before every journey that the coupling is correctly and securely positioned.

3.2 Distributing the Load Carried

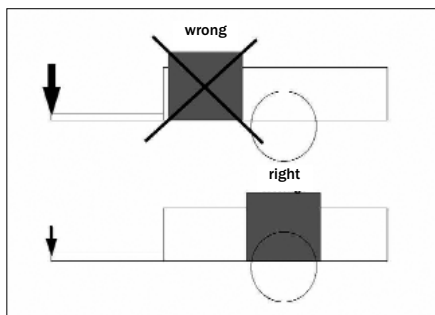

The handling of a bicycle trailer very much depends on how the load is distributed in the trailer. Too much weight in front of the wheel axles of the trailer increases the nose weight at the coupling and makes the handling and control of the bicycle harder. For this reason always load heavier objects in the area over the wheel axles. The best position for your dog, especially if it is a larger breed, is also over the axle area.

4. Safety Instructions and Warnings

Warning:

Always try to avoid going over obstacles with one wheel only, since this can lead to the trailer turning over completely, irrespective of speed.

- Always remove front stroller wheel when using the Croozer Mini as a bicycle trailer.
- Only dogs and household goods may be carried in this carrier; **it is not suitable for carrying children!**
- Never carry your dog and household goods together – your dog may be injured if the load slides around.
- Do not try to make any alterations to the carrier that are not described in this Owner's Manual.
- Before use read the User Guide carefully.
- Before setting off always fasten the coupling and safety tie correctly.
- Ensure correct assembly of all components, in particular wheels and hitch arm.
- Before setting off, check that the trailer cannot come into contact with parts of the bicycle, such as pedals and brakes etc.
- Pay particular attention to proper securing of the diagonal tube of the fabric assembly - see section 2.1.
- Attach or detach the trailer to/from the bicycle only when unladen.
- Remember that the running characteristics of your bicycle will be changed when towing a trailer, and that greater demands will be made of the brakes and load bearing capabilities of the frame. If in doubt ask your retailer.
- Cycle carefully and avoid full braking. When towing a trailer and decelerating using the front brake, the bicycle, especially its fork, are put under high loads.
- Only cyclists who are experienced and strong enough may tow trailers.
- Bicycle trailers must not be towed by motorized two-wheelers.
- Cycle more slowly and carefully with the trailer than you would if you were riding just a bicycle.
- Only take bends at walking pace, otherwise the trailer could tip.
- The maximum permissible speed for towing a bicycle trailer is 25 km/h.
- Maximum load 45 kg
- Tire pressure 2.5 bar
- When used in the dark, bicycle and trailer must be equipped with the correct lighting.
- When parking the outfit make sure it cannot tip over. Attaching a trailer changes the bicycle's centre of gravity, so that certain types of kick stands, especially double leg kickstands, cannot be used in connection with a trailer. Tipping over may damage the trailer, drawbar or the trailer coupling.
- Trailers, even when folded, must not be transported on the roof of a vehicle.
- When strolling, be sure to use the parking brake when ever stopped.
- Avoid cycling or strolling on steep hills.

5. Service, Care and Storage

5.1 Hitch Arm

Check the hitch arm regularly for signs of damage (e.g. cracks). **If there is any kind of damage whatsoever to the hitch arm, then it must be replaced so as to prevent breakage and the resulting risk of accident.**

If in doubt ask your retailer.

5.2 Wheels

Have the wheels (tyres, rims, tension of spokes, **axle bearing**) checked by your specialist dealer at least twice a year.

Clean the wheels regularly and give them a protective wax, particularly just before the onset of winter.

5.3 Fabric Assembly

Clean your CROOZER MINI using water and a rinse agent. Do not use any aggressive cleaning agents as these may permanently damage fabrics and surfaces.

5.4 Storage

Store your CROOZER MINI in a dry and well-ventilated place. Before storing your carrier, it should be dry to prevent the growth of mould and the formation of marks from mildew. Put your CROOZER MINI as little as possible in direct sunlight to prevent colours fading. Do not store the trailer coupled to the bicycle over a long period of time.

5.5 General Maintenance

Look after your carrier. All painted, chrome or galvanised parts (including screw connectors) should be regularly cleaned and protected using standard products for this purpose. Ask your specialist dealer about suitable products for protecting your trailer.

5.6 Wear Factors

Reaching the wear limit very much depends on how well the users have looked after and maintained the product as well as the particular type and intensity of use such as:

- Mileage
- Effect of load
- Type of ride
- Effects of the weather: UV rays, humidity, dirt, temperature, salty air etc.
- Storage
- Level of maintenance

Please look at the following table ('Wear factors'). You can see from this table which factors particularly affect the wear and tear on individual parts.

This table complements the existing operation guide – Please do also note the instructions on service, care and storage.

Factors, which particularly increase wear on bicycle trailers:

Wear factors		Parts				
		Fabric body	Floor, Side walls	Rims, hubs & spokes	Tires ^{*5}	Drawbar, Clutch
Loading of:	Load		xx	x	xx	xx
Influence of the weather:	UV rays	xx ^{*1}	xx		xx ^{*2}	
	Humidity	xx ^{*3}	xx	x	x	
	Dirt	xx	xx	x	x	
	Temperature	x	x		x	
	Salty air	x	xx	xx	x	xx
	Contact with salt water	xx	xx	xxx	x	xx
	Roads gritted with salt	xx	xx	xxx	x	xx
Storage		x	x		x ^{*4}	

Influences on wear and tear:

- x: Moderate effect on wear and tear
 xx: Strong effect on wear and tear
 xxx: Considerable effect on wear and tear

- *1 - If at all possible, avoid exposure to strong sun light
 *2 - If at all possible, avoid long exposure to sun light
 *3 - Avoid mould forming by storage in a dry place
 *4 - No wear and tear if stored in a hanging position
 *5 - Regularly check the tire air pressure

**Made in China for:
 Croozer Designs
 1-866-543-2766
 105 - 5760 9 Street SE
 Calgary AB T2H 1Z9 Canada
 Date of issue: 9-2008**